

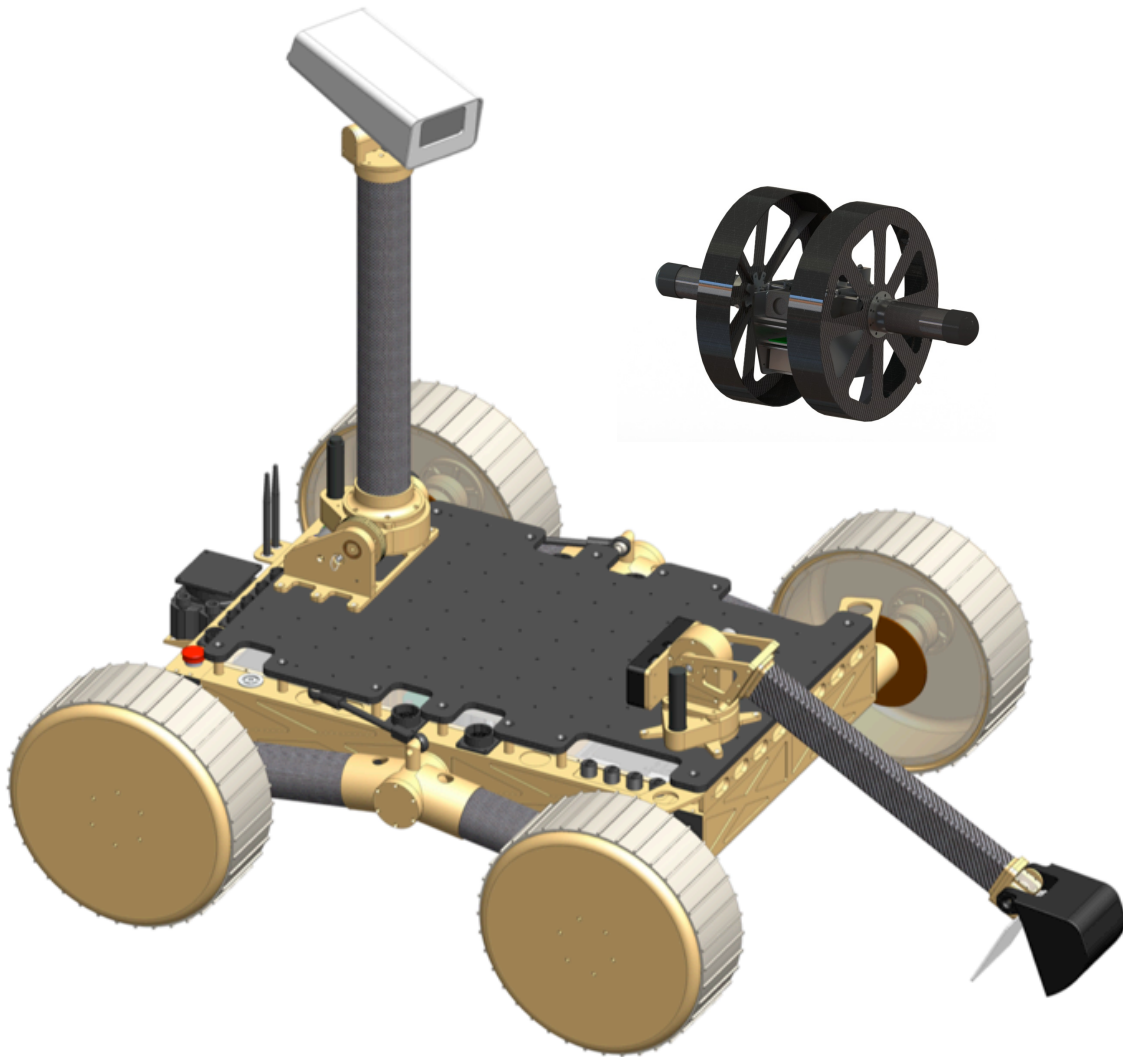

WPI

ORYX 2.1 AND THE WPI MICRO-ROVER



WORCESTER POLYTECHNIC INSTITUTE ~ TECHNICAL REPORT
NASA AND THE NATIONAL INSTITUTE OF AEROSPACE
2013 RASC-AL EXPLORATION ROBO-OPS COMPETITION

TEAM MEMBERS

ENNIO CLARETTI ~ ANDREW CUNNINGHAM
ANDREW DAVIS ~ VELIN DIMITROV
ARTHUR FULGONI ~ DAVID KELLY
RAN LI ~ QUAN PENG
STEVEN RUOTOLO ~ CODY SHULTZ
JIVESH TOLANI ~ JACOB ZIZMOR

ADVISORS

MICHAEL CIARALDI (CS)
BRADLEY MILLER (RBE)
TAŞKIN PADIR (ECE)
KENNETH STAFFORD (ME)

1 - Introduction

ORYX 2.1 is a revision of ORYX 2.0; this improved version will utilize a secondary reconnaissance rover (Micro-rover) for exploration. ORYX 2.0, from the 2012 RASC-AL Exploration Robo-Ops Competition, was a redesign on its predecessor ORYX 1.0, from the 2011 RASC-AL Exploration Robo-Ops competition. It improved mobility, sample detection, sample acquisition, and controls. ORYX 2.0 added mechanical features like a suspension, increased system ruggedness, and more sophisticated software. As another improvement to sample detection and location, the micro-rover was designed to work together with ORYX 2.1.

The Micro-rover is a secondary assistive rover, it is intended to scout ahead of ORYX 2.1 and identify sample locations. With the Micro-rover we will be able to cover more ground and it will give us an additional camera for picking up rocks when needed, a side view of the robot can help on difficult samples collection.

During the 2011 and 2012 RASC-AL Exploration Robo-Ops Competition it became clear that locating the samples was the most difficult challenge. We also found it difficult to tell how far away the rock were located, especially in inclined terrain, and how from the ground our scoop was. The Micro-rover can prove helpful in these situations.

The Micro-rover was designed with specific goals:

- A two-wheeled rover with a stabilizing tail.
- A compact chassis, between the wheels, to houses the electronics, communications and power system.
- Low center of gravity, achieve by placing the battery low in the chassis to add stability to the system.
- Provide visual feedback to the operator
- Integrated roll bars that provide the Micro-rover with the ability to self-right from any angle.

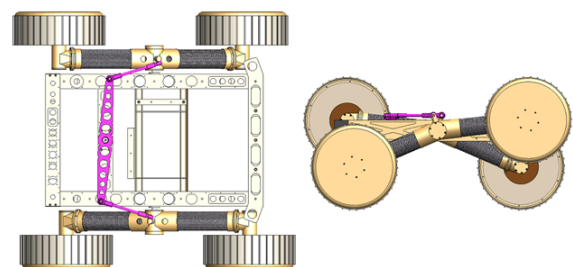

2 - System Description

2.1 - ORYX 2.1

ORYX 2.1 has a passive averaging suspension. The core components of the rover mobility system consist of the chassis, rocker linkages, differencing arm, and rocker arm, as shown in Figure 1 and Figure 2. The chassis is made from rectangular aluminum tubes, and consists of five rails welded

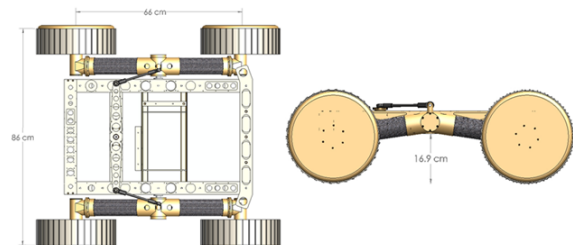

Figure 1 – Passive Averaging at Maximum and Rover Dimensions

together to form the core structure. The rocker linkages and differencing arm make up the mechanical linkage that connects each rocker arm through the chassis. This passive degree of freedom ensures that all four wheels remain in contact with the ground, which greatly improves stability and traction. The two rocker arms on either side of the chassis support two wheels each.

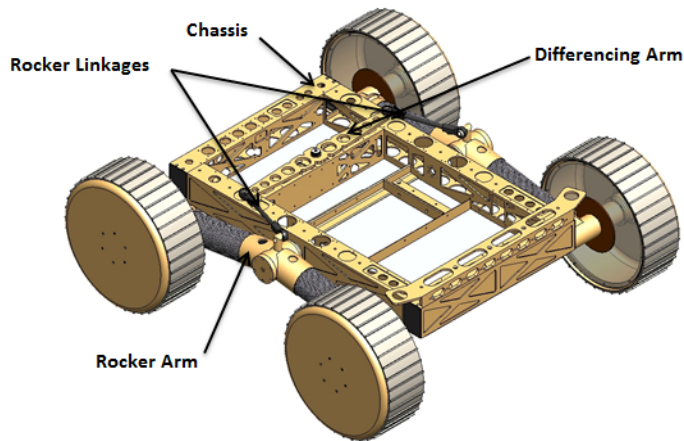

Figure 2: Chassis and Rocker Suspension Design

The rocker arms are attached to the chassis through an aluminum shaft, which is supported by two tapered roller bearings housed in the central welded assembly. The carbon fiber tubes are structurally bonded with Loctite 9430 to each side and are used to connect the wheel modules to the central pivoting

assembly, forming the main structure of the rocker arms.

The drive motors selected were Maxon's 300W 24V 4-pole brushless DC motors. Selected for high reliability and long service life these motors directly drive each wheel through a 156:1 planetary gearhead reduction; providing enough pull force to lift one quarter of the rover's weight and enough speed to travel up to 1.2 m/sec. The arm on ORYX 2.1, used to collect samples, has two degrees of freedom.

The main structure of the wheel is a 1/16" thick spun aluminum cap, 12" in diameter. Based on tread from the MER rovers and other research regarded rover tread, we selected tread with 1/8" grousers spaced ~ 1" apart; since this was offered by a standard 4" wide nitrile conveyer belt. This was attached to the aluminum wheel using 3M VHB.

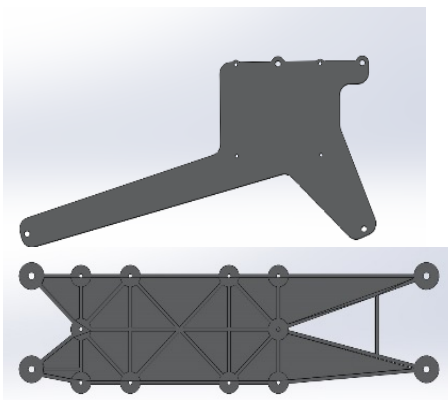

Figure 3 – new top plate designs

A major challenge on upgrading ORYX 2 to ORYX 2.1 was to make up the weight of the Micro-rover. ORYX 2 has a very rugged and reliable design which was achieved by tightly incorporating all the necessary components in a robust compact drive base. This design presented a challenge for ORYX 2.1 do to the fact that 10% of the total weight was allocated to the Mirco-rover. After extensive testing it was determined that this weight reduction could be achieved by minimizing the foot print of the camera and arm mounting plate and cutting the battery size in half, in addition to other minor modification like removing cases from components.

A new battery was designed to reduce weight. The original battery was tested to last nearly three hours. Even though having a large battery can prove useful, it is not necessary and proved to be a

simple way to cut weight. The new battery consists of 48 cells donated by Tesla Motors. Instead of soldering directly to the battery, which led to cells being damaged on the previous rover, a spring connector system is used in the new battery pack. This new battery saved four pounds.

New mounting plates were designed to reduce weight. ORYX 2 was designed with flexibility in mind; the top plate played a major role in this, by providing a mounting surface for external peripherals. For ORYX 2.1 this flexibility was removed and two mounting plates with the minimum necessary footprint to hold the camera boom, arm and sample collection box were designed, shown in Figure 3. These two new mounting plates saved over 4 pounds.

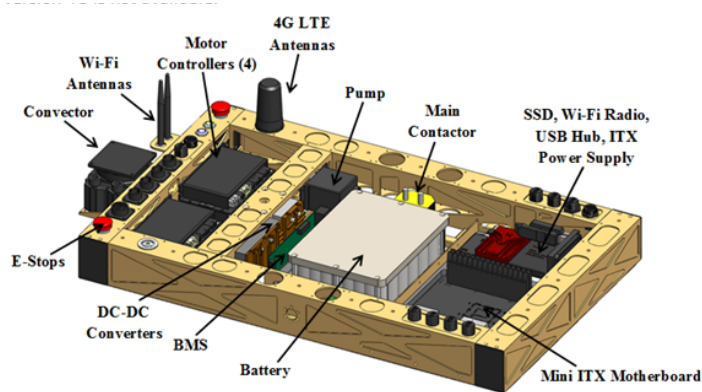

Figure 4 – internal components of ORYX 2.1

the master computer. The components can be seen in Figure 4.

ORYX 2.1 has two 720p video streams that can be transferred at ~10 frames per second over Verizon 4G by using Theora compression. One camera is located on the arm and the other is placed on top of a deployable mast that has pan-tilt functionality, shown in Figure 5. A carbon fiber tube connects the camera and tilting actuation assembly to the base.

The software looks for specific colors at adjustable thresholds, and then undergoes blob detection, overlaying circles on the graphical user interface (GUI) to alert the operator to the rocks location. This software has been tested in many scenarios and has been found to be incredibly useful for locating rocks.

The main computer is a mini ITX motherboard with a quad Core i5 processor. This high-power processor was selected so that intensive video processing and compression such as Theora could easily be achieved. Related accessories include a SSD, USB hub, ITX power supply, and Wi-Fi radio. Wi-Fi hardware is used to connect with the Micro-rover. This allows the Micro-rover to connect to

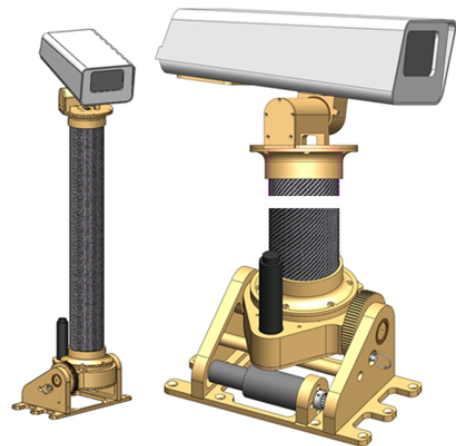

Figure 5 – pan-tilt camera on ORYX 2.1

2.2 - Micro-Rover

The design for the Micro-rover takes into account the requirements necessary for it to be used as an initial prototype for a space rated system. Because of this many of the solutions in the design were a compromise of weight, strength, cost, and manufacturing feasibility. Many of the materials were donated by various parties and, because of such, our design was modified to work with the materials we had available to us. The overall design is shown in figure 6.

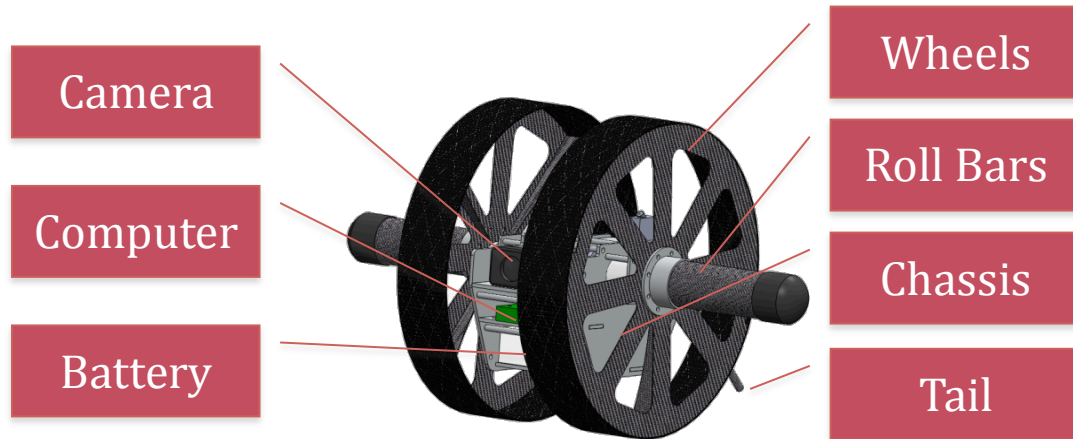

Figure 6 - Micro-rover overall design

2.2.1 - Wheels

The Micro-Rover wheels play a crucial role in the total functionality of the rover. The wheels were designed to meet the following design criteria:

- Passively self-righting on flat ground
- Able to withstand .25m drop test in earth gravity
- Able to climb 5cm step obstacle

Multiple design iterations were used to ensure the final design was capable of meeting these requirements. The final tread pattern can be found in Figure 7.

The Micro-rover wheels were designed to have the largest possible outer diameter, while adhering to the size constraints, enabling the rover to climb specified obstacle sizes, and transverse simulated lunar surfaces. These wheels are made almost entirely of rigged, meshed carbon fiber. This allows for the wheels to provide the stiffness and support necessary for driving and drop tests, while still enabling the rover to fall within mass restrictions. The wheels feature roll bars, mounted on the outer edge of each wheel, that provide a point 12.7 cm away from the wheel around which the rover can pivot to self-right.

To fulfill the requirement of climbing slopes and obstacles, a suitable traction material was selected. After experimenting qualitatively with multiple materials by testing various material types (rubber lining, wood grousers) on prototype wheels, the material shown in Figure 7 was selected. Other tradeoffs included weight and material durability. This material consisted

of deep grousers, overlaid in such a way as to prevent vibration during driving. The rubber was reinforced with canvas, and epoxied directly to the wheels carbon fiber outer rim.



Figure 7 - tread material

2.2.2 - Chassis Designs

The rover chassis is suspended freely between the two wheels, and is fully encapsulated on the interior of the rover. The chassis is built from .3175 cm (1/8") aluminum, which was water jetted into 2 side plates, and a number of shelf like structures to hold all the necessary electrical equipment. We used 7.62 cm standoffs to hold the 2 side plates of the chassis together, with the shelves setting upon grooves pre-cut into the 2 sides. The grooves and shelves are close fits, which do not hold the chassis together, but prevents the shelving aluminum plates from moving or vibrating during driving. For the motor mounts we used aluminum plates as well with 2.54 cm standoffs to keep the two motors in place. This was done by mounting the motors onto the small plates on the far sides of the chassis then mounting the plates to the chassis with the standoffs.

2.2.3 - Camera

Vision on the Micro-rover is done using a HD USB color camera in conjunction with the Overo/RoboVero, with final image processing completed on the Home Base computer. The camera was placed on the foremost point of the rover, allowing for the maximum possible line of sight around the wheels. A lens was purchased allowing the line of sight for the camera to come as close as possible to wheels without the wheels obstructing the view angle.

2.2.4 Control and Communication

The selected single board computer for the rover is the Gumstix Overo FE Com. This is a low power board with small physical dimensions (58x17x4.2mm), which specializes in processing video signals. The board also includes 802.11b/g wireless capabilities, as well as an antenna that can be mounted externally to the robot chassis. The Micro-rover connects to ORYX 2.1 through an Ad-Hoc Wi-Fi network using these wireless capabilities.

Using this board required a secondary breakout board for the power supply and USB camera, as well as to provide the necessary digital and analog pins needed for sensors and control functions. The breakout board is the Gumstix RoboVero™ board, which has the ability to communicate to motor controllers using header pins for GPIO/CAN/I2C/SPI/UART/PWM and analog signals.

The selected motor controllers for this system are those recommended by MAXON for the motor type. This is the ESCON Module 36/3, which is a small motor controller compatible

with both the Gumstix system and MAXON motor. The motor controller has configurable analog and digital inputs and outputs. These can be configured to provide the actual speed of the motors based on the Hall sensor embedded in the motors.

The software on the Micro-rover handled sensor feedback, camera image compression, and wheel control. This was implemented using a combination of custom and pre-existing Robot Operating System (ROS) nodes. The Micro-rover communicates through ORYX's ad-hoc Wi-Fi connection to mission control.

3 - Technical Specifications

3.1 - ORYX 2.1

In Table 1, the following information can be found about ORYX 2.1: dimensions, mass, rated payload, maximum speed, maximum obstacle size, operating time, drive power, battery, on-board computer, module power interface, module communications interface, system feedback and sensing, and software.

Table 1 – ORYX 2.1 technical specifications

ORYX 2.1 Technical Specifications	
Dimensions (LxWxH)	96 x 89 x 31 cm 39.9 x 34.9 x 12.2 in
Mass	41 kg 90 lbs
Rated Payload	15 kg 33 lbs
Maximum Speed	1.2 m/s 3.9 m/s
Maximum Obstacle Size	15 cm 5.9 in
Operating Time	1.5 hrs typ
Drive Power (Mechanical)	Up to 400 W continuous

Battery	22.5V 9Ah Lithium Ion w/BMS
On-Board Computer	Water- cooled Intel Quad-core i5 processor on Mini-ITX motherboard
Module Power Interface	Four accessible ports (5V / 12V / 24V)
Module Communication Interface	USB 2.0 (8) / Gigabit Ethernet (2) / Wi-Fi / 4G LTE
System Feedback and Sensing	Battery Voltages, System Temperatures, Rover Orientation, Odometry, Rocker Orientation, System Fault Handling
Software	ROS

3.2 - Micro-Rover

Included in Table 2 are the specifications for the Micro-rover for the following information: dimension, mass, maximum speed, communications, video, communication range, drop height, and battery details.

Table 2 – Micro-rover technical specifications

Micro-rover Technical Specifications	
Dimension (LxWxH)	42 x 32 x 29 cm
Mass	2.7 kg
Maximum Speed	1 m/s
Communications	Wi-Fi 802.11b/g
Video	640x480 pixels at 8 fps

Communication Range	150 m (line of sight)
----------------------------	-----------------------

Drop Height	0.25 m at 9.82 m/s ²
--------------------	---------------------------------

Battery	12.8 V 3.3 Ah LiFePO ₄
----------------	-----------------------------------

4 - Testing Strategy

4.1 - ORYX 2.1 Testing

Our testing phase primarily focused on confirming we had met our mobility goals. We also evaluated the ease of payload integration by installing and testing our sample vision payload during this phase. Lastly, data logged during the testing trials were examined to confirm that temperatures and battery voltages remained in safe limits. We tested the rover's mobility on rough terrains in the Worcester area. In general, stability and traction were very good in all terrains tested: grassy fields, rocky terrain, small gravel, dirt and sand. The selected tread performed well, easily gripping rocks and traversing vertical obstacles with almost no slipping. The suspension system was design to keep all four wheels in contact with the ground. Aside from some rare occurrences when the suspension reached its mechanical limit, it performed as it was designed. To evaluate the effectiveness of our payload integration features, we designed a deployable pan-tilt camera payload. All the design goals for this camera payload were met: deploying autonomously, panning and tilting based on current spikes, being controllable, and HD video relayed back to the GUI.

4.2 - Micro-rover Testing

Multiple tests were performed to verify that our rover meet all specifications outlined in the Problem Description section. Each test validated an aspect of the design, was performed in a manner that is repeatable and is described in detail below.

4.2.1 - Speed Testing

The maximum speed of the Micro-rover was tested by timing its runtime down a 10 meter straight length of carpeted hallway. The micro-rover was placed approximately a meter behind the starting line to ensure that it would reach its maximum speed before crossing the start. This test was repeated three times. This test was accepted as an accurate approximation of the maximum speed because potential inconsistencies in distance and speed between the runs were insignificant.

4.2.2 - Drop Testing

A simple drop test was used to test that our rover could survive the .25 meter test our simulations predicted it could. We also drove the Micro-rover off of ORYX 2.0's base plate, which is approximately 0.25 cm above ground level. The rover was never drop-tested from heights over .25 meters to prevent accidental damage to system components.

4.2.3 - Self-Righting

To test the Micro-rover's ability to right itself when tipped over, we placed the fully assembled rover in a variety of positions and attempted to right the rover's orientation without physically interacting with it. This was done during the drive testing, and not as an individual experiment. The rationale behind this type of testing was to experimentally determine all possible scenarios in which the rover would be incapable of self-righting.

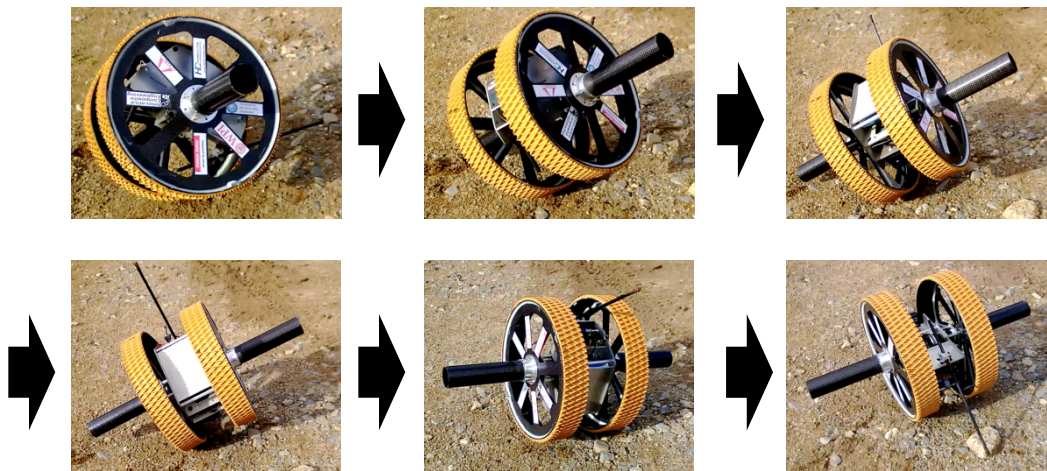

Figure 8- Micro-rover self-righting

When the rover is on flat ground, it can passively right itself. This process is illustrated in Figure 8, where the Micro-rover is driven down a hill into a position where it is resting backwards and on its side. Upon coming to rest, the rover is level on flat ground and drivable.

4.2.4 - Slope Testing

The rover's ability to climb slopes was evaluated using the following methodology:

1. Measure slope of outdoor hill with a protractor that is approximately 30° .
2. Start rover 1m from hill, then accelerate to maximum speed and allow the rover to climb hill
3. Repeat to verify

In this test, the rover successfully climbed the hill with the given specifications. The test was also performed without the 1m starting distance, and the rover torque satisfied the needs of directly climbing the hill. The rover was also tested at a higher slope (the exact angle was not measured). The findings suggested that the rover's climbing ability is limited by traction rather than motor torque.

4.2.5 - Obstacles

The rover was tested to ensure it could climb 5cm step obstacles, as well as 10cm round obstacles. The 5cm step obstacle was first simulated in a laboratory setting, using 5cm wood blocks. This was then replicated outdoors by repeating the experiment with a 6cm brick shard. Finally, a 10cm round obstacle was made out of a dirt mound. This was measured from ground level to the crest. Both tests were successful, further validating the design.

4.2.6 - Power Consumption

Since we rely on a single power source for mobility and computation understanding our power consumption rate was very important. We performed several tests in order to ensure that we would have sufficient battery life for the competition.

4.2.6.1 - Lab Testing

The first tests of our power consumption involved testing multiple scenarios in a laboratory situation. The battery was disconnected from the Custom PCB, and replaced with a power supply replicating the battery voltage. The current draw of the Micro-rover was measured under multiple loads. This procedure can be replicated using these steps:

1. Place rover on stand so wheels are free to move
2. Disconnect rover power from modular PCB connection
3. Measure battery output voltage with digital multi-meter
4. Connect power input of rover PCB to external power supply
5. Switch on power supply, then rover power switch
6. Connect to control interface on home base computer over add-hock network
7. Disable rover wheels
8. Record current draw from power supply
9. Spin motors on maximum speed (no load)
10. Record current draw from power supply
11. Place rover on pre-built 30deg slope and drive motors
12. Record current draw from power supply

After performing these steps, the following results were obtained:

Battery Voltage= 12.3V (near minimum operational charge)

Table 3 - Micro-rover power test data

	Voltage	Current	Power
Electronics & Computation Only	12.3V	.41A	5.043W
Motor Maximum Speed No Load	12.3V	.84A	10.332W
Motor on 30deg Slope*	12.3V	1.89A	23.247W

**NOTE: During this test, the 30° slope measurements may have been inaccurate due to power cable lengths. Rover was notable to accelerate completely up incline.*

4.2.6.2 - Field Testing

In an effort to test the power systems in the most complete manner possible, the systems were tested on the rover platform running from the battery while performing field tests. The two methods this was done are as follows:

Full Functionality Testing

1. Charge the rover battery supply to 13.4V (until battery draws less than .2A charge current)
2. Switch on the rover and connect to wireless network
3. Connect to wireless ad-hoc network
4. Start timer
5. Perform other field tests (without stopping for great length of time)
6. Wait for rover to stop responding or drive abnormally
7. Stop timer

Continuous Drive Testing

1. Charge the rover battery supply to 13.4V (until battery draws less than .2A charge current)
2. Switch on the rover (rover spins in place by default)
3. Start timer
4. Wait for rover to stop responding or
5. Stop timer

The results are these tests are shown in Table 4:

Table 4 - Micro-rover power test results

Test	Time
Full Functionality Testing	1h33m
Continuous Drive Testing	2h5m

4.2.7 - Testing Summary

As noted in Table 5, is a summary of the Micro-rover testing.

Table 5 - Micro-rover testing

Deliverable	Test	Result
Rover will Drive at 1m/s	Time over 10m straight line	1.056m/s
Rover will climb 30deg incline	Test on hill or at NERVE Center	Capable of driving up hill in controlled manner
Rover will self-right from any angle (not in Robo-Ops)	Test in Multiple Configurations	Successful on flat ground
Interchangeable Wheels	NA	Complete
Fall from .25m in earth	Perform multiple .25m drop	No failure at specified

gravity (landing at any angle)	tests and check for damage	distance
Rover Mass will not exceed 2.5kg	Weigh rover	2.7Kg
Rover will climb 5cm step/sheer obstacle	Test by driving over 5cm wood block	Complete
Rover will climb 10cm ramp/round obstacle	Test by driving over 10cm rock	Complete
Fits with ORYX 2.0 size constraints (1mx1mx.5m) and is deployable	Measure while mu-rover is in deployment locations. Verify that mu-rover can separate from ORYX 2.0 Platform	Complete (not with roll bars)
Will have tail for hill climbing and camera stabilization	NA	Complete

5 - Overall Strategy

Our strategy is built on our on experiences from the competition in 2012 and 2011. ORYX 2.0 did a great job efficiently collecting rocks, but had a hard time finding them. To aid in this, the Micro-rover was designed to fill a support role as a mobile camera platform. This will provide additional video and depth feedback, increasing the situational awareness of the users during the competition. ORYX 2.1 will remain the primary collector, but finding the samples will be assisted by the new micro-rover. With this division of labor we hope to do even better this year.

6 - Budget

We would like to thank our sponsors, who provided financial support, components and services: National Institute of Aerospace, NASA, MAXON Precision Motors Inc., MathWorks Inc., Innovative Composite Engineering, Tesla Motors and Hydro-Cutter. The breakdown of our spending is as follows, as noted in Table 6:

Table 6 - Budget

Micro-Rover	Price
Electronics System	\$1500
Drive System	\$1750
Mechanical Structure	\$2800
ORYX	
Electronics System	\$600
Mechanical Structure	\$1000
Shipping	\$550
Registration	\$1200
Travel & Lodging	\$3000
Total	\$12400

7 - Public Outreach

To provide public awareness of robotic space exploration missions and goals, as well as foster interest in science, technology, engineering and mathematics (STEM) fields among children and the public, our project team has participated in multiple public outreach events. These events include a Camp Reach event, the University of Massachusetts demo, display at the Smithsonian Museum, and the Cambridge Science Festival. Our first STEM outreach program was the Camp Reach Reunion event. This involved a brief presentation at a camp reunion for a program aimed at the encouragement of young female students in science and engineering fields. This program is reverent in modern society due to the lack of female students pursuing careers in science and technology within the United States. According to a study published by the National Science Foundation, Females now fill only 27% of US jobs in science and engineering fields, a figure which has increased little since a similar pole was done in the 1990's, showing only 23% females in the same fields (Board 2012). This is a concern, due to much higher increases in women working in other non-STEM fields.

The ORYX team at WPI also participated in a brief trip to the University of Massachusetts (UMASS). This was done to foster relationships between student teams, as well as between the two universities. It was hoped that this cooperation could aid in future cooperation between the two schools, including the use of the new NERVE center at UMASS for rover testing.

To aid public awareness of the importance of robotics in space exploration, our rover was displayed alongside the ORYX 2.1 platform at the Smithsonian National Air and Space Museum. This event, held during national robotics week, shows applications for robotics in space exploration, but also makes the public aware of how private organizations can participate in the development of space exploration technologies.

A final way our project team demonstrated involvement in public events was our participation in Robot Zoo pictured in Figure 9. Robot Zoo was an event held as part of the Cambridge Science Festival, and demonstrated the many applications of robotics as well as existing robotics technologies. Many corporations as well as two other universities were present at this event, and presented to an audience consisting primarily of children and interested adults in the Cambridge area. It was hoped that this interaction would foster increased interest in robotics fields, as well as inform the public about our projects role in research of space exploration technologies. During this presentation, our team demonstrated the operation of our rover over a video feed, showing how a micro-rover can be used alongside the ORYX 2.1 rover (also present).



Figure 9 – Our team at the Robot Zoo

We also engaged the public is by the use of our blog and our Facebook page. Our Facebook page currently has 304 likes. With updates on current events and our statuses, the public was able to keep up with all that we were doing for our project.

8 - References Cited

- Amato, Joseph L., Jon J. Anderson, Thomas J. Carlone, and Michael E. Fagan. *ORYX 2.0 - A Planetary Exploration Mobility Platform. Oryx 2.0: A Planetary Exploration Mobility Platform*. Worcester Polytechnic Institute, Apr. 2012. Web. 19 May 2013.
- Cunningham, Andrew, Quan Peng, Cody Shultz, and Jivesh Tolani. *Inspection and Reconnaissance Micro-Rover for Use in Extraterrestrial Environments. WPI Team ORYX*. Worcester Polytechnic Institute, Apr. 2013. Web. 19 May 2013.