

Revolutionary Aerospace Systems Concepts
Academic Linkage (RASC-AL)
Exploration Robo-Ops Competition 2012



Final Technical Report

Caltech Rover Team
California Institute of Technology

Team Organization

Team Leader	Daniel Y. Lo
Faculty Advisor	Joel W. Burdick

Design Team

Project Manager/Chief Designer	Russell G. Newman
Justin R. Koch	Mary H. Nguyen
Jeffrey T. Picard	Alejandro M. Sanchez
David T. Flicker	Ahalya Prabhakar
Solomon Chang	Hima J. Hassenruck-Gudipati
Bryan D. He	Alexander W. Wilson
Harrison J. Miller	

Education and Public Outreach Team

Ingrid M. Fiedler	Pinting Chen
Ellen M. Price	Naoki Eto
Jungsoo Park	

Acknowledgments

We would like to thank the following:

- The National Institute of Aerospace (NIA) for organizing the competition
- The National Aeronautics and Space Administration (NASA) for the sponsorship
- John van Duesen, Supervisor for Caltech's Mechanical Engineering Shop, for his technical assistance
- Michael Rauls, Melissa Tanner and Reeve Dunne, ME graduate students at Caltech, also for their technical assistance
- Dr. Issa Nesnas, from the Jet Propulsion Laboratory, for his guidance in the design of the rover, and also for giving a lecture as part of our Education and Outreach Activities
- Maria Koeper, Prof. Burdick's assistant, for her assistance in the administrative and financial aspects of the competition
- Moya Chen, for her article about the competition and the team in the California Tech, Caltech's weekly newsletter
- James Maloney, Coordinator for the Caltech Classroom Connection, for giving us the opportunity to showcase our rover to middle school students as part of a larger STEM outreach program
- Everyone else who has given us suggestions on the rover design, and also supported us through our various social media

Contents

I.	Executive Summary	1
II.	Rover Systems.....	2
a)	Mobility System	3
b)	Sample Acquisition System.....	3
c)	Navigation	4
d)	Power System	5
e)	Computing Hardware	5
f)	Signals and Controls	6
g)	Software	6
h)	Additional Features	7
III.	Rover Construction and Testing.....	8
IV.	Education and Public Outreach.....	9
a)	Engaging the General Public	9
b)	Engaging Students.....	10
	Appendix 1. Power Wiring Diagram	11
	Appendix 2: Signal Wiring Diagram	12
	Appendix 3: FEM Stress Analysis of Wheel Mount	13
	Appendix 4: Images of Rover.....	14

I. Executive Summary

The RASC-AL Exploration Robo-Ops Competition is an engineering competition sponsored by National Aeronautics and Space Administration and organized by the National Institute of Aerospace. This competition challenges undergraduate and graduate students to build a planetary rover prototype and demonstrate its capabilities in a series of competitive tasks in field tests at the NASA Johnson Space Center's Rock Yard. The rover is required to be controlled from the home university campus via a commercial broadband wireless uplink, relying solely on information transmitted through cameras or other sensors on board the rover. In addition, teams are also required to engage the public through a series of Education and Public Outreach (EPO) programs.

The key requirements for the rover are:

- Size: No larger than 1 m x 1 m x 0.5 m in stowed configuration
- Weight: less than or equal to 45 kg
- Be able to traverse over obstacles up to 10 cm in height
- Be able to negotiate 33% grade slopes
- Be able to pick up and transport at least 5 irregularly shaped rocks with diameters 2-8 cm and masses 20-150 g
- Be able to determine the color (red, purple, blue, green, yellow, or orange) of rocks
- Be able to traverse sand with no appreciable slope over at least 20 feet
- Operable in light rain
- Communication link: Verizon 3G/4G broadband card, with typical data rates of ~0.6Mb/s download and ~0.4Mb/s upload, and latency of 150-300 ms

This report presents the design of the rover as conceived by the Caltech Rover Team. The Caltech Rover Team is a multi-disciplinary team of undergraduate students from the California Institute of Technology. The design calls for four independently-driven wheels placed in a rocker system under the rover chassis, allowing the rover to effectively transverse uneven terrain and over obstacles. Navigation is done mostly using cameras mounted on top of a deployable mast. A six degree-of-freedom arm at the front of the rover with a gripper at the end will be used to pick up the rocks, guided by cameras mounted on the arm. These rocks are then placed in the on-board sample collector. The communications link with the rover will be established via the two Verizon 4G broadband cards on board the rover.

The Caltech Rover Team has also organized several events to satisfy the EPO component of the competition. In addition to updates about the team's progress through Youtube videos and short Facebook and Twitter status updates, we have also conducted a public lecture, organized outreach events for local middle school students, engaged with FIRST teams from local high schools, and showcased the rover to the general Caltech population.

II. Rover Systems

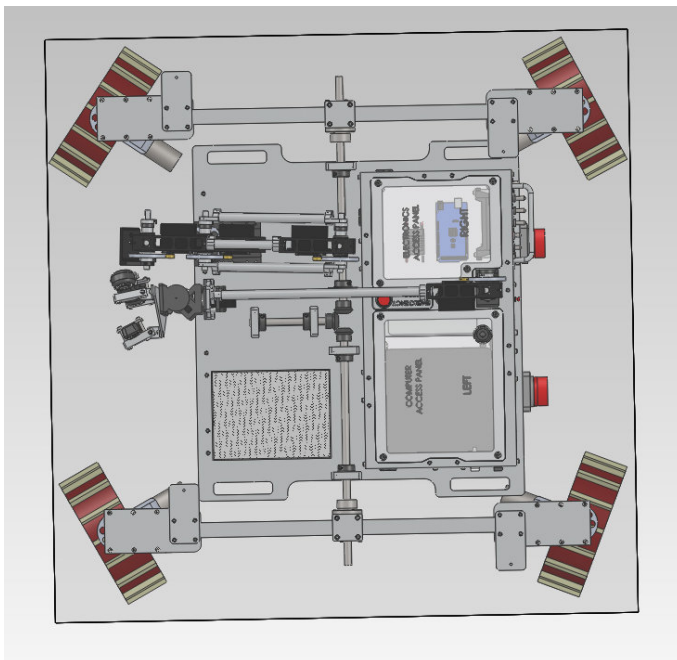
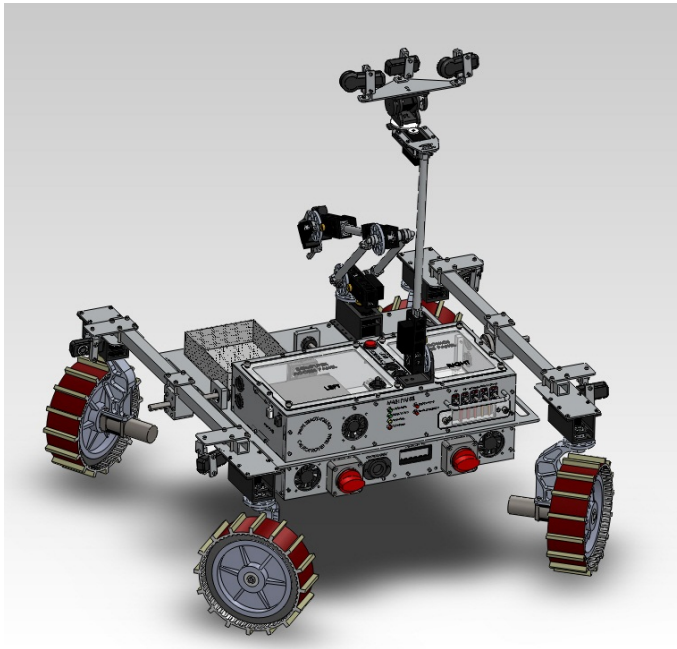

Quick Facts

Mass	38.5 kg
Size	1 m x 1 m x 0.5 m
Drive	4 Wheels Swerve Drive
Average Speed	4 mph
Battery Life	2 hours
Arm DOF	6
Number of Cameras	8
Network	WiFi/Verizon 4G LTE
Programming Language	C++

Fig 1. Back and Top View of Rover

a) Mobility System



Fig 2. Side View of Rover showing Rocker System

In order to satisfy the requirement of being able to drive over obstacles up to 10 cm in height, the rover makes use of the rocker mobility system, providing passive suspension to keep the rover from flipping over the uneven terrain. In the rocker system, four independently driven wheels of diameter 20 cm are mounted on the ends of two arms on opposite sides of the chassis. The arms are connected by a passive differential with steel rods extending to each arm, and the chassis is mounted to the differential. This allows the chassis to remain relatively level, with the angle between the chassis and the ground the average of the angles the arms make with the ground. This rocker system has a long heritage, and an enhanced version (the rocker-bogie system) has been implemented in NASA's rovers to Mars specifically for its effectiveness over rough terrain. A bungee cord is strapped between the arms under the chassis to dampen out oscillations when the rover travels over uneven terrain.

The wheels are powered by a BaneBots PDX104 geared motor, providing 67.23 Nm of torque which is easily enough for a rover of this mass to drive over obstacles in the Rock Yard. Drawing a mere 1.5 A continuously, these motors also ensure the rover's endurance over the entire 1-hour duration of the competition. Each wheel is independently steerable, connected to the arm by a rotational joint driven by Hitec HS-785HB servos through a 5 to 1 torque increasing gearbox. These servos by themselves provide 1.2925 Nm of torque at 1.8 A. The pivot of the rotational joint is directly over the point of contact between the wheel and ground, minimizing the power required to turn the wheels. With their metal gear upgrade to support higher loads, these servos form the backbone of the full omni-swerve drive system that gives the wheels over 180 degrees of rotation, allowing the rover to move laterally in any direction, as well as spin in place. In line with the design requirements, grousers are fitted to the wheels to increase traction over sandy terrain, and covers are placed over the spokes to prevent rocks from being inadvertently lodged in the wheels. Individual wheels can also be boosted to spin faster than the rest should the rover become partially stuck. Overall, the design of the mobility system provides high precision and maneuverability at the expense of speed, a justifiable trade-off given the small size of the JSC Rock Yard and the small size of the targets.

b) Sample Acquisition System

The rover has a 6 degree-of-freedom arm mounted on the front, and a two-pronged gripper is fitted to the end of this arm. Also powered by Hitec HS-785HB servos, the arm is capable of lifting 0.5 kg at full extension, sufficient for picking up any rock samples or alien life forms. Connected via linkages attached to Hitec 645MG servos, the gripper is designed for flexibility, allowing the operator fine control of the gripper position. The servos give a torque of 0.939 Nm, translating to a gripping force of 0.071 N. Samples are deposited in the sample collector positioned next to the arm. This sample collector is

constructed out of aluminum mesh, and is secured to the deck of the rover using Velcro. Although not necessary under the design requirements, this allows the samples to be quickly removed by detaching the entire collector from the rover.

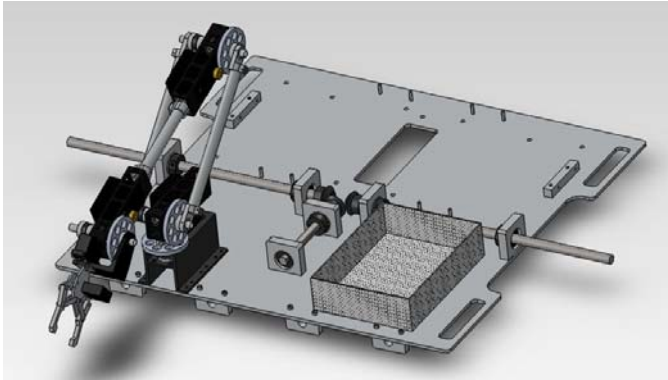

Fig 3. Sample Acquisition System

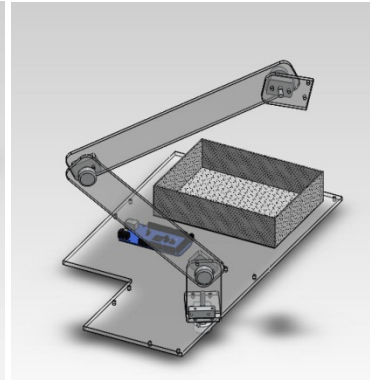

Fig 4. Model Arm Interface

The movement of the rover arm is controlled through a master-slave system. The model arm interface has potentiometers corresponding to each of the servos on the actual arm. The operator will insert his thumb and index finger into the end of the model arm interface, and attempt to pick up a virtual rock in front of him. These movements will be transmitted to the actual arm on the rover. A switch on the side allows the master-slave interface to be turned off when the arm is not in use. The servos for the gripper are controlled through two separate buttons.

c) Navigation

Navigation is conducted using video feed from the eight USB webcams mounted on the rover. Two Logitech QuickCam Pro's are mounted directed 60° from each other on the pan-tilt mast to provide the driver a survey of the terrain and allow identification of targets. A further QuickCam Pro is mounted on the arm to provide the detail required for sample acquisition. There are also five lower-resolution Logitech C310 cameras on board. One is placed over each wheel as a hazard camera, giving vision of the opposite wheel for safely negotiating obstacles. The last C310 camera is mounted on the pan tilt mast but pointed down to provide a view of the immediate front of the rover. The C310 cameras are lower quality but have a smaller footprint which is important in the small space near the wheels and the underside of the mast. In contrast, the QuickCam Pro's have higher resolutions and provide a clear and a wide field of view for driving and targeting. These Logitech cameras are selected for their low cost and easy integration into the Linux operating system on the rover computer through their generic USB webcam driver.

The mast comprises a pan-tilt system mounted on top of a bar, providing a vantage point of 1 m above the ground for navigation. Originally in a stowed position, the mast will be raised by a Hitec HS-785HB servo at its base, and then locked magnetically to prevent oscillations. The pan-and-tilt system is powered by Hitec HS-785HB servos.



Fig 5. Mast

d) Power System

The rover contains four 12 V 5.0 Ah NiMH batteries connected in parallel that provide all the rover's systems with power (see Appendix 1). The motor controllers connect directly to the unregulated, nominal 12 V supply. The computer is supplied a regulated 12 V by a 25 W CUI buck-boost module with filter capacitors and a transient voltage suppressor diode. This module is selected because for its rated power being sufficient to power the 20 W computer and its ease of integration, thus accelerating development time. The 12 V regulator also features a 2.5 A diode on the positive supply to minimize the voltage drop when the motors controllers are turned on. This voltage drop is found to be significant enough to cause the computer to shut off, and cannot be controlled by the filter capacitors which are also being discharged. This diode thus keeps the regulator insulated from the motor controllers and prevents the filter capacitors from discharging to charge the motor controller. The wheel and mast servos are powered by two SportBEC 3.5 A 6 V regulators while a CC-BEC Pro 20 A 6 V regulator powers the six servos on the arm. This split regulator design is used to split the current load and reduce the maximum amperage required per regulator. It also allows the powering of only one portion of the servos for testing. The Arduino Mega, USB hub, status LEDs, and buttons are powered by a Pololu 5 V regulator. Power control is provided by five toggle switches on the back of electronics box for each regulator. There are also two large locking knobs on the back of the rover, one of which is a master power control and the other is for motor power. Circuit protection is provided by 10 A automotive fuses on each of the voltage regulator supplies. A battery status LCD on the back of the rover displays the current battery voltage, current draw, power draw, and energy provided since the last power cycle, giving an indication of the remaining power. The batteries can be recharged using the socket on the back panel of the rover.

The cooling system comprises six 80mm fans, four in the power box and two on the electronics box, powered by the unregulated 12 V supply.

e) Computing Hardware

The computing architecture comprises the two Pantech Verizon 4G LTE USB modems plugged into a Jetway AMD-based nettop connected to the Arduino Mega by USB. The Pantech modems have external antennae outside of the solid aluminum electronics box which acts as a strong Faraday cage. The nettop has a dual core 1.6 GHz AMD E-350 processor for running the JPEG compression of the camera feed and transferring control information to the Arduino. The load on the CPU while running the compression code is only 65%, thus giving us a large margin. The nettop is also ideal in the constrained environment on the rover, given its small size and thermal footprint. Also, it only requires a single 12 V input instead of multiple voltages typical of desktops. The storage system is an Intel 120 GB SSD which provides the superior vibration resistance necessary for travelling over uneven terrain as compared to traditional HDDs. The Arduino Mega provides fourteen PWM outputs which is just enough for the number of servos on the rover and can easily be connected to the nettop through USB. The Arduino Mega connects to all of the servos, powers the status LEDs, reads the state of the buttons, and controls the motors. The Arduino Mega also has robust library support and breaks the pins out to headers allowing for easy connection to other components.

On the driver end, an Intel Q6600-based desktop connects to the Caltech network, another Arduino Mega, a joystick and a monitor. The joystick controls the rover while the Arduino Mega reads the angle of each joint of the model arm interface by measuring the changing voltage of the potentiometers as it moves. The positions of the arm and the joystick are translated into servo and motor commands on the rover by

the process described later in section IIg) Software. The monitor displays the camera feeds returned from the rover for navigation.

f) Signals and Controls

To better manage the power and signal distribution to the servos, a custom-built servo board with three 6V inputs is used to connect to the Arduino Mega over two ribbon cables (see Appendix 2). There are fourteen servo headers on the board connected to one of the 6 V supplies, ground, and a PWM output from the Arduino Mega. The board allows easy swapping of servos and better cable management in the confined box. There is also a custom 5 V power board that distributes 5 V to all of the devices that need it with built in current limiting resistors for the status LEDs and pull-down resistors for the buttons and connects these devices to the Arduino Mega. Finally, it connects a TX pin from the Arduino Mega to the two 1-wire serial inputs to the motor controllers along with ground. The Arduino Mega signals the motor controllers using packetized serial. The motor controllers themselves provide forward, reverse and brake capabilities to the rover. There are eight USB webcams and one Arduino Mega connected to the computer via a powered USB hub that is connected to the rover computer. The status LEDs and buttons are connected to the Arduino Mega via the 5 V board to digital I/O pins. When either the start or e-stop button is pressed, it causes the IO pin it is connected to to be pulled high, generating an interrupt that is handled by the Arduino Mega. The reset microcontroller button is connected to the Arduino Mega's reset pin and when pressed causes that pin to be pulled low which directly causes the Arduino Mega to reset.

g) Software

All software is written in C++ and compiled with the gcc compiler or the avr-gcc compiler for Arduino code. The system runs on either the i686 or x86_64 of Arch Linux, a free light-weight Linux distribution.

Communication in the control elements configuration can be divided into two categories: serial communication and TCP communication. TCP communication is implemented using the Berkeley Sockets API embedded within the standard Linux kernel. The server computer (or the driver computer) runs an implementation of this API that waits for a socket connection from the rover computer (the nettop on the rover) remotely. Once connection is established, the software uses the full functionality of TCP in order to insure packet order and arrival. This connection is pulsed at 60 Hz in order to confirm continued connection and provide accurate data for the rover in its execution.

Serial communication is implemented using the termios serial IO embedded within the standard Linux kernel. A file handler is created and pooled at 10 Hz in order to confirm continued connection and provide accurate data for the rover. This uses the serial-to-USB emulation of the Arduino Mega. Both the server and the rover computer are connected to Arduino Megas. Standard open-source Arduino Serial IO libraries that accompany distributions of the Arduino microcontrollers are used on the Arduino side of the communication interface.

The joystick connected to the server using the kernel file handling which is pooled at a rate depending on the current CPU clock frequency of about 100Hz. The Arduino Mega connected to the rover computer communicates with the two Sabertooth motor controllers using a packetized serial protocol, using standard Arduino Serial IO libraries for the Arduino end of the interface. Additionally, the Arduino on the rover controls the various servos via pulse width modulation using the standard PWM libraries of the Arduino distribution. The Arduino Mega connected to the server uses the standard Arduino analog libraries to read from the several potentiometers on the model arm interface.

The actual control system is a robot state machine that collects the desired state from the joystick and the server Arduino Mega. The current state is given by limited feedback mechanisms from the rover Arduino Mega. Thus this implementation resembles an open loop controller more than fully fledged closed loop robot state machine. The algorithm receives the input values from the joystick and server Arduino Mega and returns the command values to be sent to the various servos and motors. The server is simply responsible for pooling the server Arduino Mega and the joystick and sending those values to the rover computer. The majority of the computation is done on the rover to minimize data that has to be sent over the costly TCP communication interface. All code is rigorously tested to ensure tractability (polynomial execution time) and maximize the limited computation resources present on the rover. On the rover, the rover computer will receive these input values, run the algorithm described above, and send these values over the serial interface to the Arduino Mega. All values sent over the communication interfaces are checked for feasibility and lack of data corruption before being executed or computed. Although this costs computational overhead, this safety check is necessary to ensure physical integrity of the rover.

The joystick used is a three-axis joystick that requires nonstandard implementation to interpret this third axis with regards to the swerve drive implemented in the drive system. The algorithm separates drive train control decisions into two categories: those that includes this third dimension and those that do not. With those that do not, the algorithm is simple. Compute the angle necessary to maneuver the rover in the desired direction as symbolized by the joystick's current position, slew the servos to the correct location, and command the motors to a speed based on the magnitude of the vector described by the joystick's current position. With the third dimension, a perpendicular angle to that of the current joystick position is computed. This is the axis of desired rotation. The required degrees of rotation per second is then computed using the magnitude of the third coordinate of the joystick position. These values are incorporated into the drive values taken from commanding the drive train without the third dimension. This algorithm is found to run in about five milliseconds on the equivalent of an Intel Atom processor. Thus it is highly efficient, and the computational overhead in performing this algorithm on the limited resources of the rover is minimal.

h) Additional Features

The design of the rover also includes additional features to increase its robustness. The fans on the electronics box have filters to protect the sensitive electronics inside from the dusty environment of the Rock Yard. Air coming through the fans is also passed over silica gel to minimize the possibility of condensation, and as a form of protection against light rain. The rover also has handles on its sides for easy and safe handling.

III. Rover Construction and Testing

The design of the rover is done entirely in Solidworks 2012 Student Edition.

The rover comprises a total of 837 parts, of which 155 are unique. To ease construction, parts are designed to have simple shapes so they can be easily built on a mill by hand. For parts that are more irregularly shaped, they are purely planar and so can be cut using a water jet machine. The design also calls for captive nuts that are Arbor pressed rather than tapped holes, reducing the likelihood of mistakes and reducing build time. The access panels on the electronics box are cut and engraved using a ULS 160W laser cutter system. The user-interface panels at the back of the rover are engraved using special marking paint and the laser cutter.

The wheel mounts, having to bear the entire weight of the rover and thus receive the most stress, is one of the most complicated parts of the robot. This part is designed to be very light and strong by using Solidworks Simulation Toolbox which includes Finite Element Analysis tools (see Appendix 3). After a prototype was created through an iterative design process, it was built out of ABS plastic using a 3D printer to check that everything was perfect before the four copies of the actual part was CNC'ed using a Fadal Vertical Milling Center. The CNC code was programmed using HSM Xpress CNC modeling.

Hardware is standardized to #8-32 socket head cap screws, making up 80% of the total. The remainder is split between #10-32 and #6-32. #5-40 is used for the pre-built hubs used in the arm. This simplicity allows the entire rover to be constructed using three hex keys and the #1 and #2 screwdrivers.

There are two phases in the testing of the rover. In the building phase, the team has adopted a "build-on" approach. This approach involves integrating newly built parts with the rest of the rover and testing them as these new parts are built. This approach allows the team to overcome its primary weaknesses of limited manpower and the reliance on the specialized skills of several individuals by focusing all its efforts on tackling a single problem at a time. In the second preparation phase, testing is conducted under conditions similar to those at the competition. Each test session lasts much longer in this phase than in the building phase, and sees the rover completing the same tasks as those required in the competition under conditions even harsher than expected at the competition venue. In this way, not only will any problems be readily discovered, the strategy for acquiring targets and navigation can be honed. This testing also allows rover drivers to be accustomed to the interface and their intuition in translating the video feeds to the mental picture of the surroundings necessary for effective navigation.

IV. Education and Public Outreach

The Education and Public Outreach (EPO) program of the Caltech Rover Team takes a two-pronged approach. The first involves raising awareness of the public to robotic technologies, and promoting enthusiasm in the Science, Technology, Engineering and Mathematics (STEM) fields. The second focuses exclusively on middle to high school students who are already interested in the field.

a) Engaging the General Public

Generating public interest is critical in ensuring scientific and technological progress. Leadership in advancing space technology naturally falls on the shoulders of NASA, which as a government agency can be successful only with the public's support. Furthermore, being in a competition funded by taxpayers' dollars, the Caltech Rover Team finds public involvement obligatory as a means to redirect the benefits back to the general population. In view of this, the team has employed various methods in generating interest in the general public:

1. Regular updates through Facebook, Twitter and Youtube
Social media is a highly effective and low-cost means of reaching out to a large audience. Thus the team has maintained an active Facebook page and Twitter account, allowing the team to post short regular updates about the team's progress. Some of these updates also include photographs. In addition to the required team video and mid-point review video, the Caltech Rover Team has also been posting video updates, giving a sneak peak behind the scenes. The Youtube channel also links to general robotics videos. All these enables the public to not only join in the excitement and adventure of the competition, but also to treat this as an educational opportunity to understand some of the processes and considerations in designing the rover. At the time of writing, we have 54 likes for our Facebook page, and 599 video views on Youtube.
2. Team Website
The team has also maintained a website which provides general information about the team and the competition. Furthermore, it provides in greater technical detail the design principles and considerations for the rover. At the time of writing, Google Analytics has recorded 180 unique visitors from 17 different U.S. cities since the launch of the website.
3. Mailing List
Anyone who is interested in general robotics is able to subscribe to the mailing list through the team website. Subscribers will receive weekly emails of robotics news compiled from a variety of online sources, giving them a convenient means to keep abreast of the latest developments in the field.
4. Public Lecture
The Caltech Rover Team contacted Dr. Issa Nenas from the Jet Propulsion Laboratory to give a public lecture about his research and the latest robotic technologies in space exploration. The lecture, titled "Robotic Exploration of Planetary Bodies", was held at Caltech Cahill Hameetman Auditorium on 13 April, and attracted an audience comprising both Caltech students and professors and members of the public.
5. Campus Outreach

The team organized a demonstration of the rover outside the campus cafeteria during the lunch hour on 4 May, showcasing the rover's capabilities and explaining the rover's various systems to fellow students, staff members and visitors to the campus.

b) Engaging Students

Today's students will be the engineers of tomorrow. Thus it is important to not only inspire students' interest in the STEM fields, but also to develop and guide them in their paths to become leaders who will continue to push the frontier of our technological capabilities. Hence the Caltech Rover Team has organized some activities specifically for middle and high school students who already have some kind of involvement in robotics. These activities aim to expose the students to opportunities available to them to further their interest in the field, and possible paths they can take towards a career in engineering.

1. School Tours

The Caltech Rover Team, partnered with the Caltech Classroom Connection, organized a tour of Caltech for about 200 middle school students from the Pasadena Unified School District on April 10. This tour includes not only a tour around the school, introducing them to the various aspects of college life, but also a showcase of the rover and a discussion of the design of the various systems. Using the Robo-Ops Competition as an example, the team also introduced various opportunities for the students to be involved in robotics.

2. Outreach to Local FIRST Teams

Taking advantage of the FIRST experience of many team members, the Caltech Rover Team has also reached out to various FIRST teams in the area, especially in schools which some of the members are alumni of. Although no large scale event has been organized, frequent interactions at the individual level has allowed various team members to share in greater detail both technical experience and guidance in possible career paths.

Appendix 1. Power Wiring Diagram

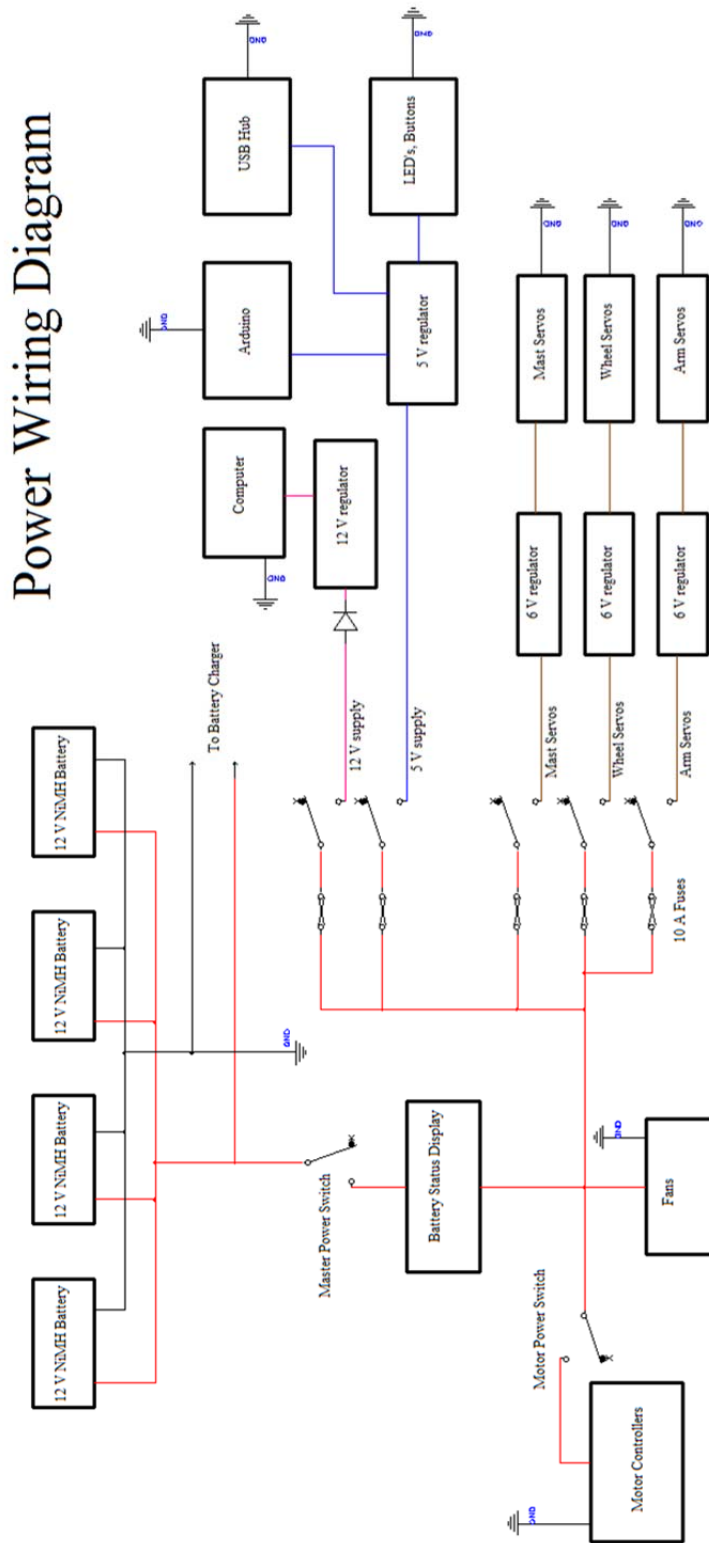

Appendix 2: Signal Wiring Diagram

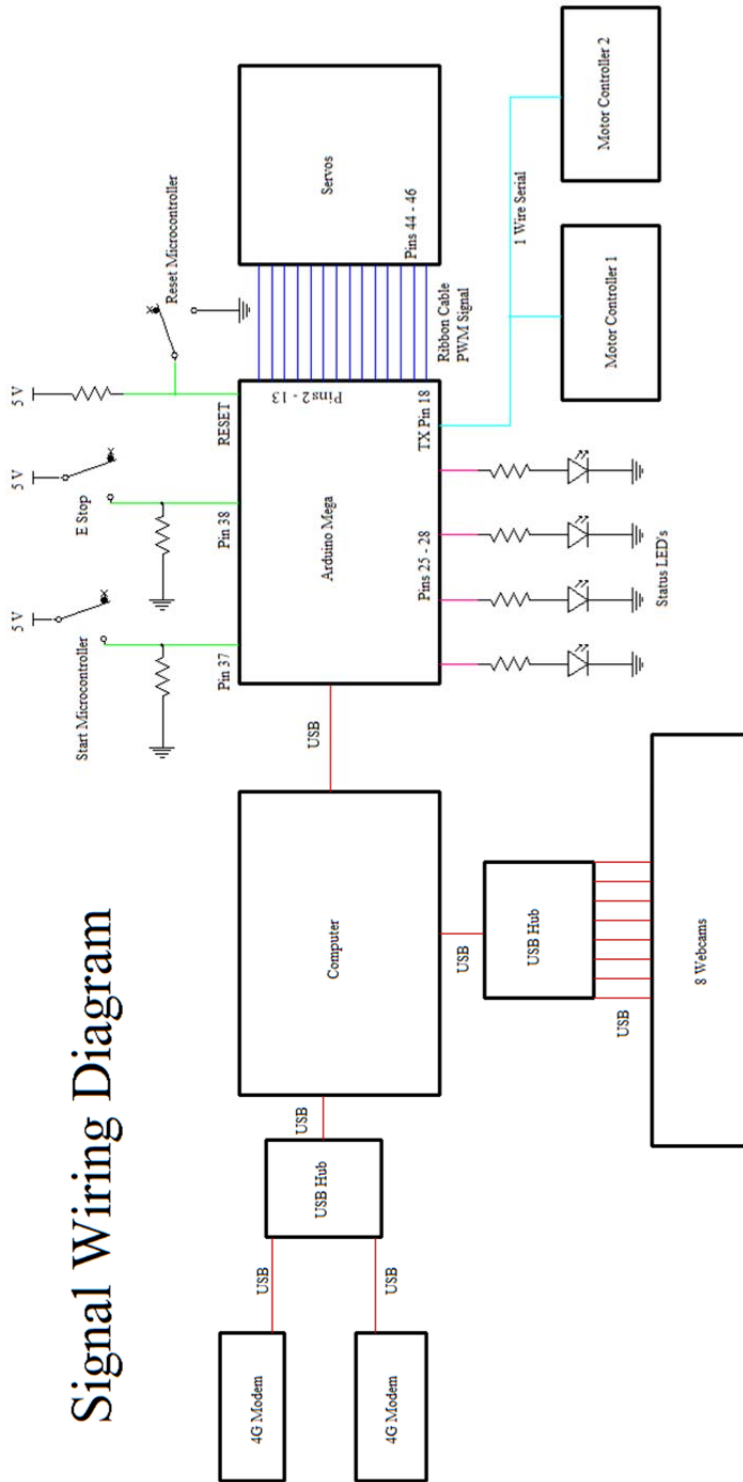

Appendix 3: FEM Stress Analysis of Wheel Mount

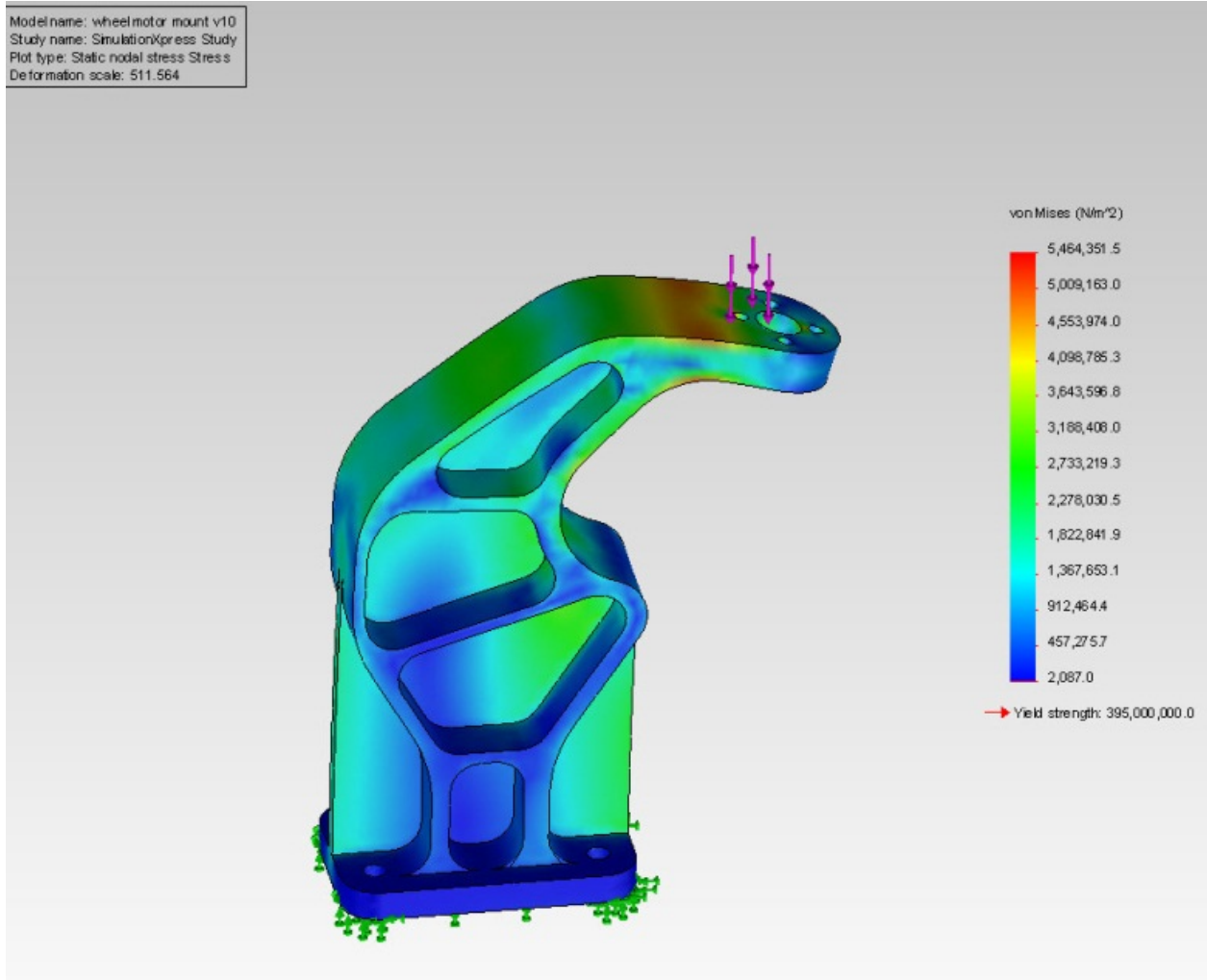

Appendix 4: Images of Rover

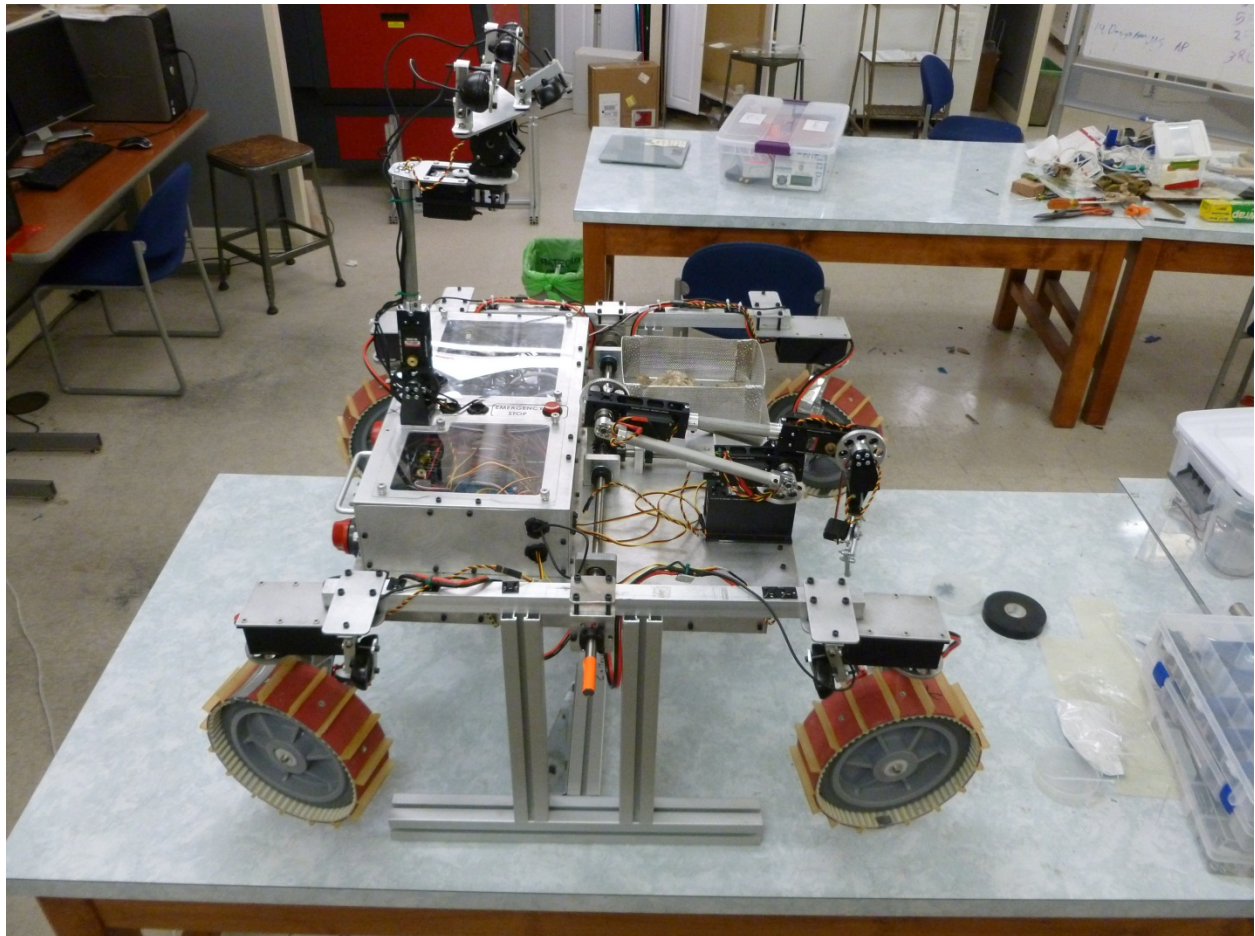

Side View of Rover

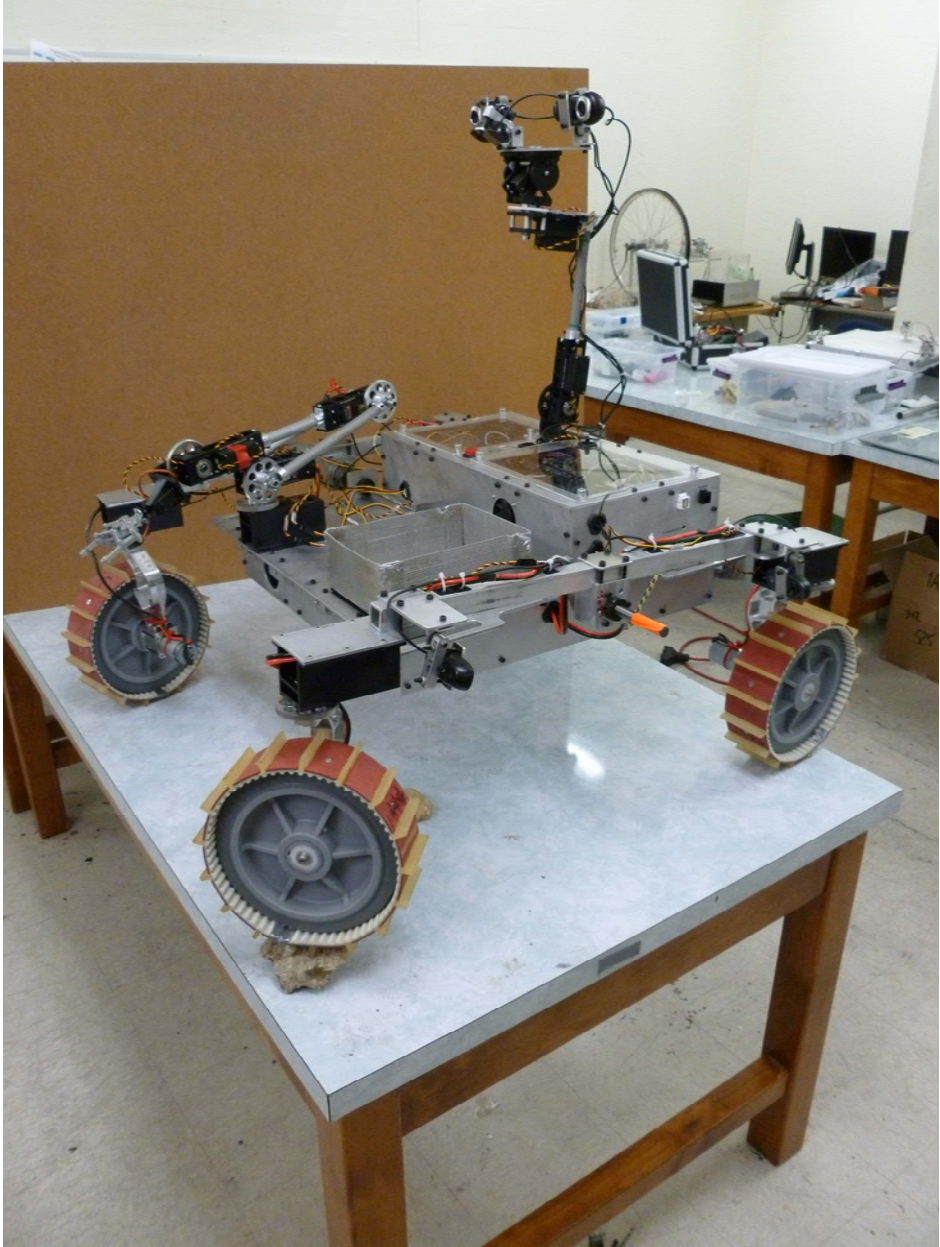

Side View Showing the Rocker System

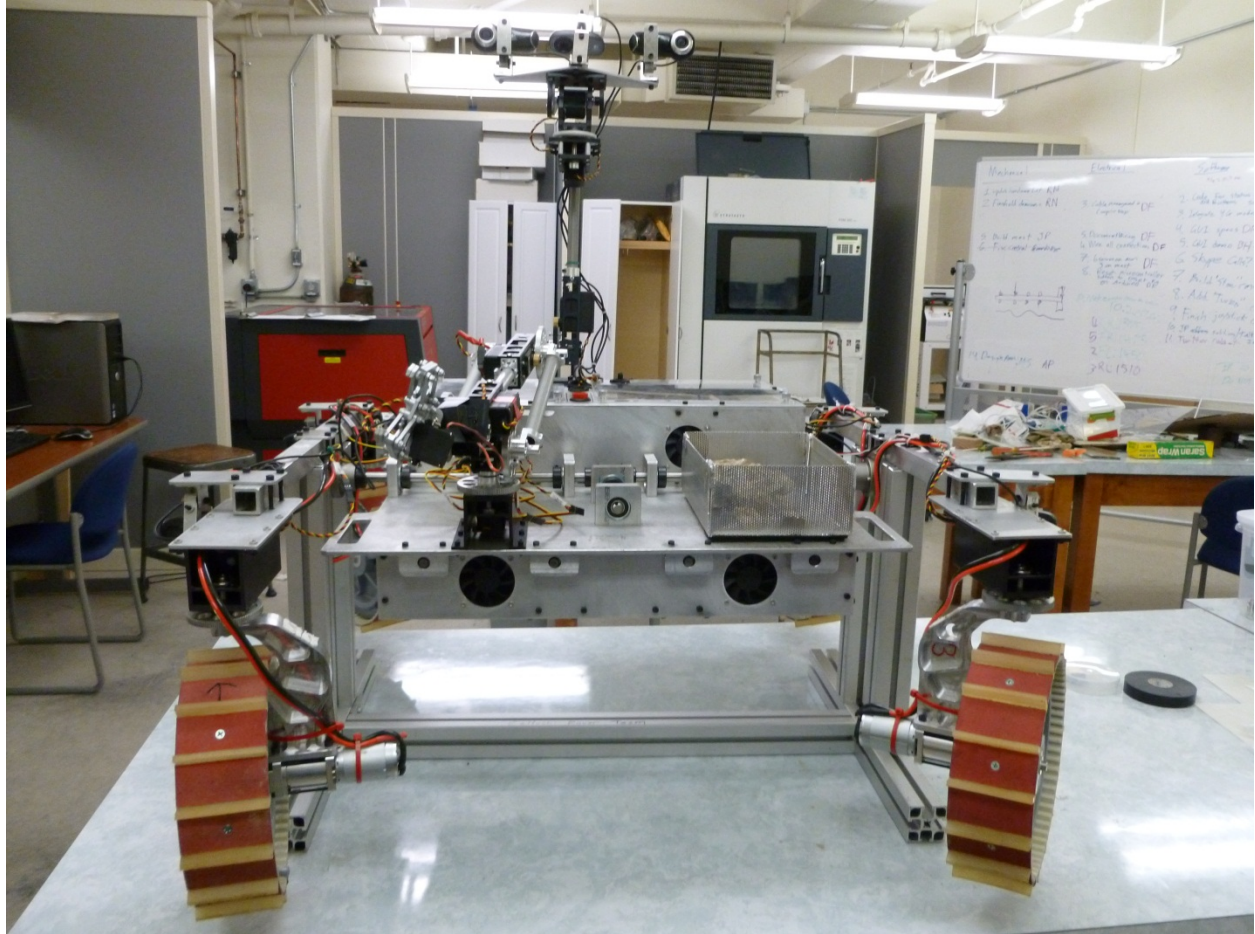

Front View of Rover with Deployed Mast

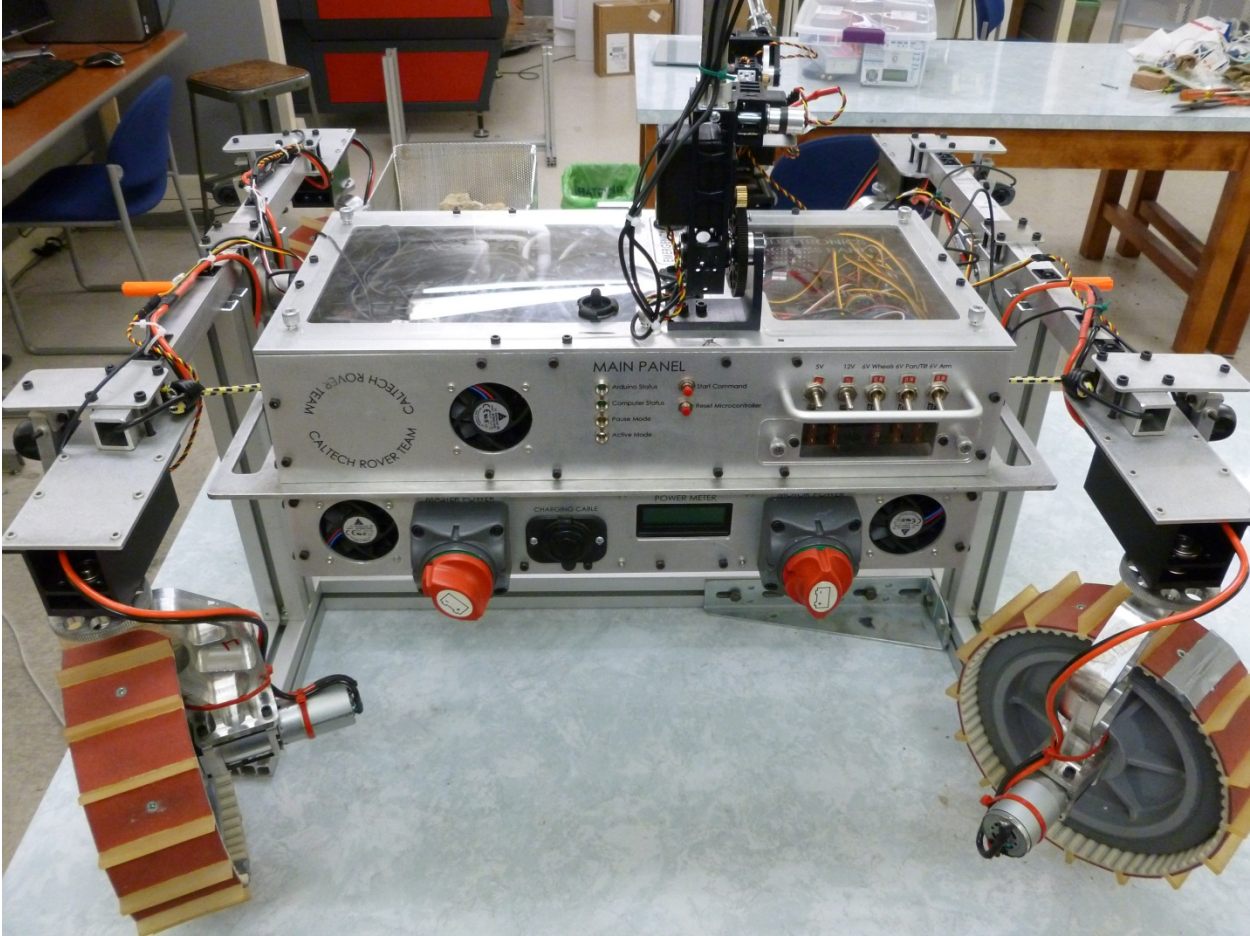

Back View Showing Electronics Panel

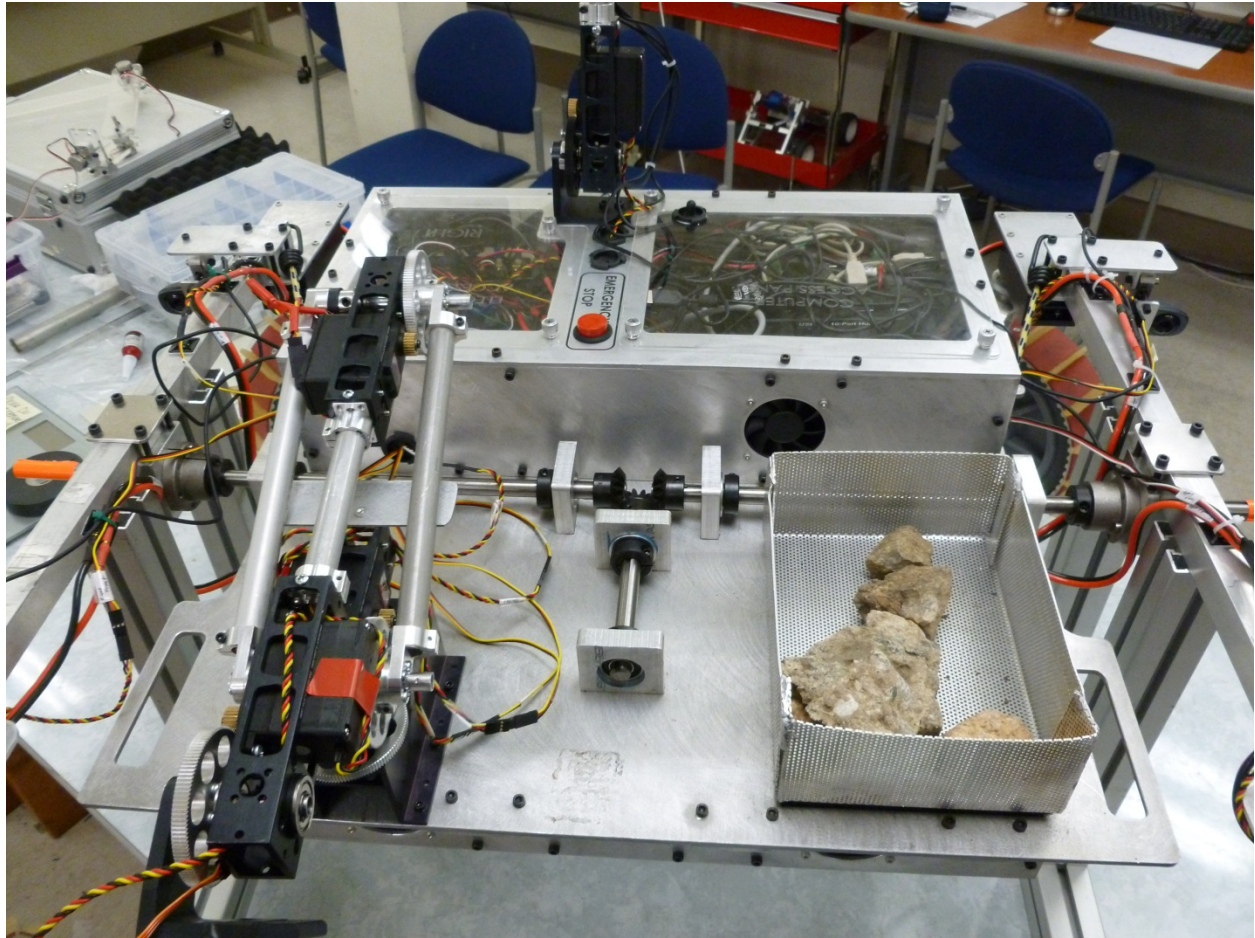

Top View of Rover with Electronics Box and Sample Acquisition System

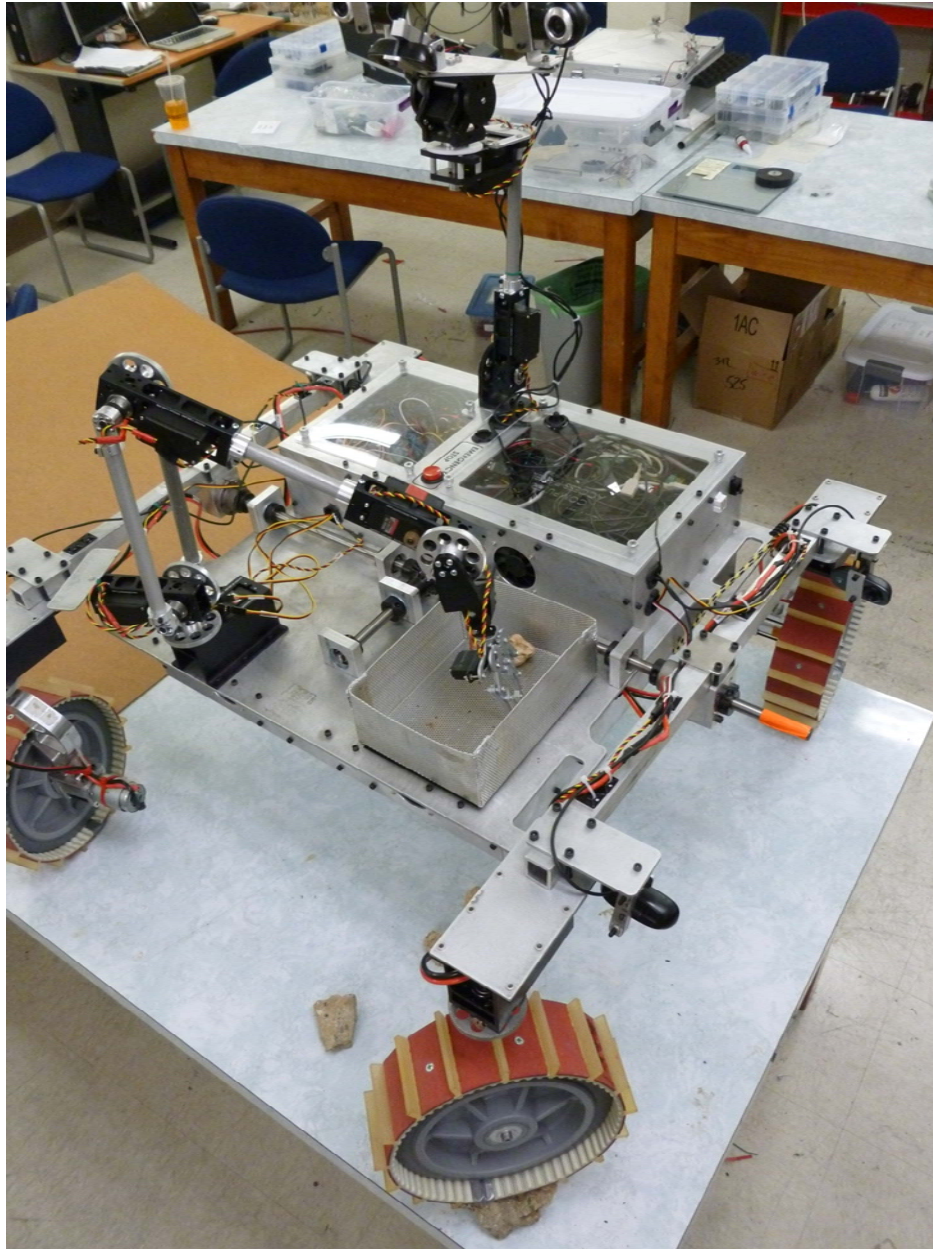

Top View of Rover Showing the Sample Collection Process

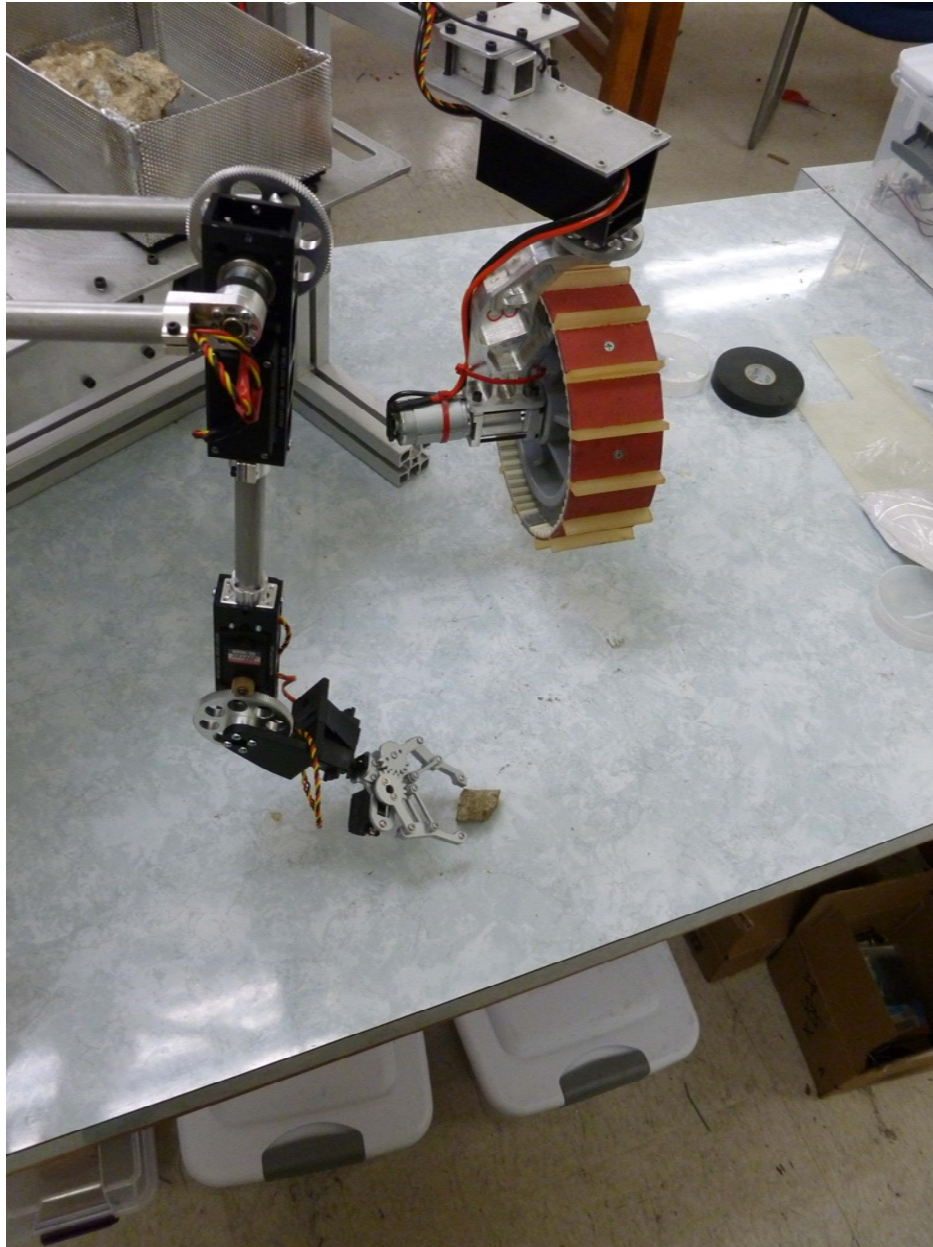

Robotic Arm with Gripper at a Rock